

ROTAIR



SPECIAL
ROW

PORTABLE
COMPRESSORS
GENERAL RANGE

GOMMAIR | DS
MOVN | D | MOVS
VRK | TVR | VRH

PRO
SERIES



A Reliable
CHOICE!

delivering
WORLD-CLASS Compressors





MDVN 22 K - 26 K



DESIGN WITH MODERN, SLENDER AND AGGRESSIVE LINE.

ELECTRO-GALVANIZED BODYWORK AND CHASSIS WITH ADVANCED PAINTING PROCEDURE TO GRANT AN EXCELLENT PRESERVATION THROUGH TIME.

LIGHT WEIGHT AND COMPACT DIMENSIONS FOR EASY HANDLING AND OPTIMUM DIMENSIONS / DELIVERED POWER RATIO.

- › Filters "spin-on" type for quick maintenance
- › Full accessibility for easy and rapid maintenance and service.
- › European homologation for road circulation with and without brakes.
- › Exclusive pneumatic control system, developed by ROTAIR, to adjust automatically engine revs, depending on the air to be delivered. This system is highly reliable and ensures fuel consumption saving.
- › Air/oil separator filter, highly oversized, can guarantee an excellent air/oil separation.
- › The air and oil filters of the compressor and the air and oil filters of the engine are independent.
- › Single stage oversized air filter for compressor part, to guarantee good filtering of the air intake by airend.
- › Two-stage air filter for engine part.
- › Combined radiator allowing both compressor oil cooling and engine liquid cooling.



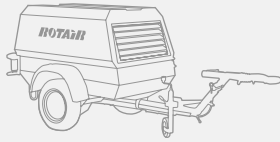

MDVN 22 K

480 kg / 1060 lbs (without brakes)
 545 kg / 1200 lbs (with brakes)
 430 kg / 948 lbs (with skid adapters)

MDVN 26 K

540 kg / 1190 lbs (without brakes)
 605 kg / 1330 lbs (with brakes)
 490 kg / 1080 lbs (with skid adapters)

COMPRESSOR

Operating pressure	6,5 bar 94 psi	10 bar 145 psi	12 bar 174 psi	6,5 bar 94 psi	10 bar 145 psi	12 bar 174 psi
Free Air Delivery	2000 lt/min 71 cfm	1600 lt/min 56 cfm	1400 lt/min 49 cfm	2500 lt/min 88 cfm	1900 lt/min 67 cfm	1400 lt/min 49 cfm
Minimum working pressure	5,5 bar - 80 psi			5,5 bar - 80 psi		
Drive system engine-aiend	Belt-drive			Belt-drive		
Compressor cooling system	Air / Oil			Air / Oil		
Oil cooling capacity	6 lt - 1.32 UK gal			6 lt - 1.32 UK gal		
Outlet valves	2 x 3/4"			2 x 3/4"		
Noise level EECno 2000/14	< 98 LWA			< 98 LWA		
Battery capacity	12V cc - 450A - 55Ah (EN)			12V cc - 680A - 55Ah (EN)		
Fuel tank capacity	30 lt - 6.6 UK gal			30 lt - 6.6 UK gal		
Consumes	3,7 lt/h - 0.81 UK gal (8,2 working hour)			3,7 lt/h - 0.81 UK gal (8,2 working hour)		

DIESEL ENGINE

Engine make	KUBOTA	KUBOTA
Engine type	D902-E4B	D1105-E4B
Engine system	4 strokes - Inline	4 strokes - Inline
Emissions	Stage V / Tier 4	Stage V / Tier 4
Displacement	898 cc	1123 cc
N. cylinders	3	3
Aspiration	Natural	Natural
Max engine power @3600 rpm	18,5 kW - 25 CV	18,5 kW - 25 CV
Max engine speed	3600 rpm	2900 rpm
Min engine speed	1900 rpm	1900 rpm
Cooling system	Water	Water
Cooling system capacity	3,7 lt - 0.81 UK gal	4 lt - 0.88 UK gal
Lubrication system	Oil	Oil
Lubrication sys capacity	4 lt - 0.88 UK gal	5,1 lt - 1.12 UK gal

QUALITY OF AIR

Oil in air	1-3 PPM	1-3 PPM
Compressed air temperature	Ambient +40°C +72°F	Ambient +40°C +72°F

ENVIRONMENTAL CONDITIONS

Max altitude	1800 m a.s.l.	1800 m a.s.l.
Min/Max working temp.	-10°C / +50°C 14°F / 122°F	-10°C / +50°C 14°F / 122°F



MDVN 26 Y



DESIGN WITH MODERN, SLENDER AND AGGRESSIVE LINE.

ELECTRO-GALVANIZED BODYWORK AND CHASSIS WITH ADVANCED PAINTING PROCEDURE TO GRANT AN EXCELLENT PRESERVATION THROUGH TIME.

LIGHT WEIGHT AND COMPACT DIMENSIONS FOR EASY HANDLING AND OPTIMUM DIMENSIONS / DELIVERED POWER RATIO.

- › Filters "spin-on" type for quick maintenance
- › Full accessibility for easy and rapid maintenance and service.
- › European homologation for road circulation with and without brakes.
- › Exclusive pneumatic control system, developed by ROTAIR, to adjust automatically engine revs, depending on the air to be delivered. This system is highly reliable and ensures fuel consumption saving.
- › Air/oil separator filter, highly oversized, can guarantee an excellent air/oil separation.
- › The air and oil filters of the compressor and the air and oil filters of the engine are independent.
- › Single stage oversized air filter for compressor part, to guarantee good filtering of the air intake by airend.
- › Two-stage air filter for engine part.
- › Combined radiator allowing both compressor oil cooling and engine liquid cooling.



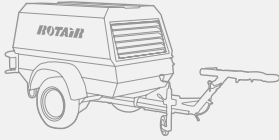

MDVN 26 Y

525 kg / 1157 lbs (without brakes)

600 kg / 1323 lbs (with brakes)

475 kg / 1047 lbs (with skid adapters)

COMPRESSOR

Operating pressure	6,5 bar 94 psi	10 bar 145 psi	12 bar 174 psi
Free Air Delivery	2500 lt/min 88 cfm	1900 lt/min 67 cfm	1400 lt/min 49 cfm
Minimum working pressure	5,5 bar - 80 psi		
Drive system engine-airend	Belt-drive		
Compressor cooling system	Air / Oil		
Oil cooling capacity	6 lt - 1.32 UK gal		
Outlet valves	2 x 3/4"		
Noise level EECno 2000/14	< 98 LWA		
Battery capacity	12V cc - 680A - 55Ah (EN)		
Fuel tank capacity	30 lt - 6.6 UK gal		
Consumes	3,8 lt/h - 0.84 UK gal (8 working hour)		

DIESEL ENGINE

Engine make	YANMAR
Engine type	3TNV76 - XCY12D
Engine system	4 strokes - Inline
Emissions	Stage V A
Displacement	1116 cc
N. cylinders	3
Aspiration	Natural
Max engine power @3200 rpm	16,9 kW - 23 CV
Max engine speed	3200 rpm
Min engine speed	1900 rpm
Cooling system	Water
Cooling system capacity	4 lt - 0.88 UK gal
Lubrication system	Oil
Lubrication sys capacity	5,1 lt - 1.12 UK gal

QUALITY OF AIR

Oil in air	< 3 PPM
Compressed air temperature	Ambient +40°C +72°F

ENVIRONMENTAL CONDITIONS

Max altitude	1800 m a.s.l.
Min/Max working temp.	-10°C / +50°C 14°F / 122°F



MDVN 31K-37K



DESIGN WITH MODERN, SLENDER AND AGGRESSIVE LINE.

ELECTRO-GALVANIZED BODYWORK AND CHASSIS WITH ADVANCED PAINTING PROCEDURE TO GRANT AN EXCELLENT PRESERVATION THROUGH TIME.

LIGHT WEIGHT AND COMPACT DIMENSIONS FOR EASY HANDLING AND OPTIMUM DIMENSIONS / DELIVERED POWER RATIO.

- › Filters "spin-on" type for quick maintenance
- › Full accessibility for easy and rapid maintenance and service.
- › Exclusive pneumatic control system, developed by ROTAIR, to adjust automatically engine revs, depending on the air to be delivered.
- › This system is highly reliable and ensures fuel consumption saving.
- › Start/stop "INTELLIGENT SYSTEM", exclusive from ROTAIR, to prevent the risk of incorrect procedures during specific functioning.
- › Air/oil separator filter, highly oversized, can guarantee an excellent air/oil separation.
- › The air and oil filters of the compressor and the air and oil filters of the engine are independent.
- › Single stage oversized air filter for compressor part, to guarantee good filtering of the air intake by airend.
- › Two-stage air filter for engine part.
- › Combined radiator allowing both compressor oil cooling and engine liquid cooling.



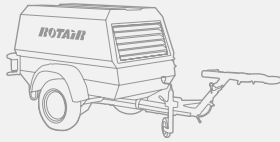

MDVN 31 K

625 kg / 1377 lbs (without brakes)
 700 kg / 1543 lbs (with brakes)
 570 kg / 1257 lbs (with skid adapters)

MDVN 37 K

625 kg / 1377 lbs (without brakes)
 700 kg / 1543 lbs (with brakes)
 570 kg / 1257 lbs (with skid adapters)

COMPRESSOR

	7 bar 102 psi	10 bar 145 psi	12 bar 174 psi	7 bar 102 psi	10 bar 145 psi	12 bar 174 psi
Operating pressure						
Free Air Delivery	3000 lt/min 106 cfm	2500 lt/min 88 cfm	2000 lt/min 71 cfm	3600 lt/min 127 cfm	3000 lt/min 106 cfm	2250 lt/min 79 cfm
Minimum working pressure	5 bar - 73 psi			5 bar - 73 psi		
Drive system engine-airend	Direct Drive			Direct Drive		
Compressor cooling system	Air / Oil			Air / Oil		
Oil cooling capacity	8 lt - 1.76 UK gal			8 lt - 1.76 UK gal		
Outlet valves	2 x 3/4"			2 x 3/4"		
Noise level EECno 2000/14	< 98 LWA			< 98 LWA		
Battery capacity	12V cc - 680A-74Ah (EN)			12V cc - 680A - 55Ah (EN)		
Fuel tank capacity	50 lt - 11 UK gal			50 lt - 11 UK gal		
Consumes	4,5 lt/h - 0.99 UK gal/h (11 working hours)			5 lt/h - 1.1 UK gal/h (10 working hours)		

DIESEL ENGINE

Engine make	KUBOTA	KUBOTA
Engine type	V1505-E2B	V1505-E2B
Engine system	4 strokes - Inline	4 strokes - Inline
Emissions	Stage III A / Tier 4 Interim	Stage III A / Tier 4 Interim
Displacement	1498 cc	1498 cc
N. cylinders	4	4
Aspiration	Natural	Natural
Max engine power	24,5 kW - 33 CV @2650 rpm	26,2 kW - 35,6 CV @3000 rpm
Max engine speed	2650 rpm	3000 rpm
Min engine speed	1600 rpm	1600 rpm
Cooling system	Water	Water
Cooling system capacity	5 lt - 1.1 UK gal	5 lt - 1.1 UK gal
Lubrication system	Oil	Oil
Lubrication sys capacity	6 lt - 1.32 UK gal	6 lt - 1.32 UK gal

QUALITY OF AIR

Oil in air	1-3 PPM	1-3 PPM
Compressed air temperature	Ambient +40°C +72°F	Ambient +40°C +72°F

ENVIRONMENTAL CONDITIONS

Max altitude	1800 m a.s.l.	1800 m a.s.l.
Min/Max working temp.	-10°C / +50°C 14°F / 122°F	-10°C / +50°C 14°F / 122°F



MDVN 31P-37P



DESIGN WITH MODERN, SLENDER AND AGGRESSIVE LINE.

ELECTRO-GALVANIZED BODYWORK AND CHASSIS WITH ADVANCED PAINTING PROCEDURE TO GRANT AN EXCELLENT PRESERVATION THROUGH TIME.

LIGHT WEIGHT AND COMPACT DIMENSIONS FOR EASY HANDLING AND OPTIMUM DIMENSIONS / DELIVERED POWER RATIO.

- › Filters "spin-on" type for quick maintenance
- › Full accessibility for easy and rapid maintenance and service.
- › Exclusive pneumatic control system, developed by ROTAIR, to adjust automatically engine revs, depending on the air to be delivered.
- › This system is highly reliable and ensures fuel consumption saving.
- › Start/stop "INTELLIGENT SYSTEM", exclusive from ROTAIR, to prevent the risk of incorrect procedures during specific functioning.
- › Air/oil separator filter, highly oversized, can guarantee an excellent air/oil separation.
- › The air and oil filters of the compressor and the air and oil filters of the engine are independent.
- › Single stage oversized air filter for compressor part, to guarantee good filtering of the air intake by airend.
- › Two-stage air filter for engine part.
- › Combined radiator allowing both compressor oil cooling and engine liquid cooling.



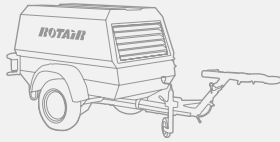

MDVN 31 P

650 kg / 1433 lbs (without brakes)
 660 kg / 1455 lbs (with brakes)
 630 kg / 1389 lbs (with skid adapters)

MDVN 37 P

650 kg / 1433 lbs (without brakes)
 660 kg / 1455 lbs (with brakes)
 630 kg / 1389 lbs (with skid adapters)

COMPRESSOR

	7 bar 102 psi	10 bar 145 psi	12 bar 174 psi	7 bar 102 psi	10 bar 145 psi	12 bar 174 psi
Operating pressure						
Free Air Delivery	3000 lt/min 106 cfm	2500 lt/min 88 cfm	2000 lt/min 71 cfm	3600 lt/min 127 cfm	2900 lt/min 102 cfm	2250 lt/min 79 cfm
Minimum working pressure	5 bar - 73 psi			5 bar - 73 psi		
Drive system engine-aiend	Direct Drive			Direct Drive		
Compressor cooling system	Air / Oil			Air / Oil		
Oil cooling capacity	8 lt - 1.76 UK gal			8 lt - 1.76 UK gal		
Outlet valves	2 x 3/4"			2 x 3/4"		
Noise level EECno 2000/14	< 98 LWA			-		
Battery capacity	12V cc - 680A-74Ah (EN)			12V cc - 680A-74Ah (EN)		
Fuel tank capacity	40 lt - 8.8 UK gal			40 lt - 8.8 UK gal		
Consumes	4,7 lt/h - 1.03 UK gal/h (8,7 working hours)			4,9 lt/h - 1.08 UK gal/h (8,2 working hours)		

DIESEL ENGINE

Engine make	PERKINS	PERKINS
Engine type	403D-15	403D-15
Engine system	4 strokes - Inline	4 strokes - Inline
Emissions	Stage III A / Tier 3	Stage III A / Tier 3
Displacement	1496 cc	1496 cc
N. cylinders	3	3
Aspiration	Natural	Natural
Max engine power	24 kW - 32,6 CV @ 2700 rpm	25,1 kW - 34,1 CV @ 3000 rpm
Max engine speed (work)	2700 rpm	3000 rpm
Min engine speed	1900 rpm	1900 rpm
Cooling system	Water	Water
Cooling system capacity	5 lt - 1.1 UK gal	5 lt - 1.1 UK gal
Lubrication system	Oil	Oil
Lubrication sys capacity	5 lt - 1.1 UK gal	6 lt - 1.32 UK gal

QUALITY OF AIR

Oil in air	1-3 PPM	1-3 PPM
Compressed air temperature	Ambient +40°C +72°F	Ambient +40°C +72°F

ENVIRONMENTAL CONDITIONS

Max altitude	1800 m a.s.l.	1800 m a.s.l.
Min/Max working temp.	-10°C / +50°C 14°F / 122°F	-10°C / +50°C 14°F / 122°F



MDVN 32B

NEW**STAGE V
COMPLIANT
PETROL ENGINE**

**3200 L/MIN AT 7 BAR PRESSURE
THANKS TO ITS 40 HORSEPOWER
PETROL ENGINE.**

**THIS PERFORMANCE,
OTHERWISE ONLY ACHIEVABLE
WITH AN ELECTRONICALLY
CONTROLLED COMMON RAIL
STAGE V DIESEL ENGINE WITH
EXHAUST GAS AFTER-TREATMENT,
MAKES THE MDVN 32B MODEL
A HIGHLY PERFORMING AND
SUSTAINABLE ALTERNATIVE.**

- › Filters "spin-on" type for quick maintenance.
- › Full accessibility for easy and rapid maintenance and service.
- › Exclusive pneumatic control system, developed by ROTAIR, to adjust automatically engine revs, depending on the air to be delivered. This system is highly reliable and ensures fuel consumption saving.
- › Start/stop "INTELLIGENT SYSTEM", exclusive from ROTAIR, to prevent the risk of incorrect procedures during specific functioning.
- › Air/oil separator filter, highly oversized, can guarantee an excellent air/oil separation.
- › The air and oil filters of the compressor and the air and oil filters of the engine are independent.
- › Single stage oversized air filter for compressor part, to guarantee good filtering of the air intake by airend.
- › Radiator allowing for compressor oil cooling.
- › Operating running costs lower than a Diesel engine of the same power.



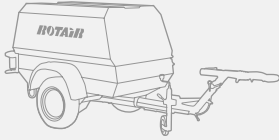

MDVN 32B

545 kg / 1202 lbs (without brakes)
620 kg / 1367 lbs (with brakes)
480 kg / 1058 lbs (with skid adapters)

COMPRESSOR

Max operation pressure	7 bar 102 psi	10 bar 145 psi	12 bar 174 psi
Free Air Delivery	3200 l/min 113 cfm	2200 l/min 78 cfm	1900 l/min 67 cfm
Minimum working pressure	4,5 bar - 65 psi		
Drive system engine-airend	Belt driven		
Compressor cooling system	Air / Oil		
Oil cooling capacity	7 lt - 1.5 UK gal		
Noise level EECno 2000/14	< 97 LWA		
Battery capacity	12V cc - 45Ah		
Fuel tank capacity	60 lt - 13.2 UK gal		
Consumes	max 12,2 lt/h - 2.7 UK gal/h		

PETROL ENGINE

Engine make	Briggs&Stratton
Engine type	Petrol
Engine system	4 strokes
Emissions	Stage V compliant
Displacement	993 cc
N. cylinders	2
Aspiration	Natural
Max Engine speed	3100 rpm
Min Engine speed	1800 rpm
Cooling system	Air
Lubrication system	Oil
Lubrication system capacity	2,4 lt - 0.53 UK gal

QUALITY OF AIR

Oil in air	1-3 PPM
Compressed air temperature	Ambient +40°C +72°F

ENVIRONMENTAL CONDITIONS

Max altitude	1800 m a.s.l.
Min/Max working temperature	-10°C / +48°C 14°F / 118°F



MDVN 34E

NEW

INNOVATIVE
ELECTRIC
SOLUTION

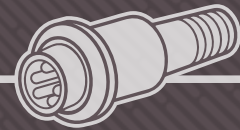

DESIGNED TO PROVIDE
COMPRESSED AIR TO THE
CONSTRUCTION SITES WITHOUT
USE OF ENDOTHERMIC ENGINES.

THANKS TO THIS INNOVATIVE
SOLUTION, THE MACHINE CAN
WORK ALSO WHERE DIESEL
ENGINES ARE PROHIBITED.

- › Quiet and suitable for use in residential areas, areas with noise restrictions, and urban areas where the use of thermal engines for construction machinery is prohibited.
- › High reliability and fewer problems of wear and degradation of parts compared to internal combustion engines.
- › Zero CO₂ emissions in an ecological green deal perspective. Suitable for use in closed environments or environmentally sensitive areas.
- › Less maintenance and less prone to failures.
- › Ease of use and quick start-up.
- › Lower long-term operating costs.
- › Longer life of the machine.



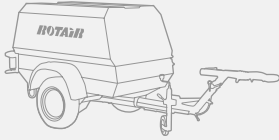

MDVN 34E

680 kg / 1499 lbs (without brakes)
690 kg / 1521 lbs (with brakes)
630 kg / 1389 lbs (with skid adapters)

COMPRESSOR

Max operation pressure	7 bar 102 psi	10 bar 145 psi	12 bar 174 psi
Free Air Delivery	3400 l/min 120 cfm	3000 l/min 106 cfm	2100 l/min 74 cfm
Minimum working pressure	4,5 bar - 65 psi		
Drive system engine-airend	Direct		
Compressor cooling system	Air / Oil		
Oil cooling capacity	7 lt - 1.5 UK gal		
Noise level EECno 2000/14	< 97 LWA		

ELECTRIC MOTOR

Electric motor make	Siemens
Electric motor type	22,0kW - 400V - 3P - 50Hz
Engine start	star/delta
Electroventilator	3,0kW - 400V - 3P - 50Hz
Max Engine speed	3000 rpm
Cooling system	Air
Total Absorbed Electrical Power	25 kW
Consumption	200 kW/day (with 8h of work)
Connection	Electrical outlet 5 poles or pentapolar
Type of electrical outlet	380V pentapolar
Rated current	40A

QUALITY OF AIR

Oil in air	1-3 PPM
Compressed air temperature	Ambient +40°C +72°F

ENVIRONMENTAL CONDITIONS

Max altitude	1800 m a.s.l.
Min/Max working temperature	-10°C / +48°C 14°F / 118°F





MDVN 46 K - 53 K



DESIGN WITH MODERN, SLENDER AND AGGRESSIVE LINE.

ELECTRO-GALVANIZED BODYWORK AND CHASSIS WITH ADVANCED PAINTING PROCEDURE TO GRANT AN EXCELLENT PRESERVATION THROUGH TIME.

LIGHT WEIGHT AND COMPACT DIMENSIONS FOR EASY HANDLING AND OPTIMUM DIMENSIONS / DELIVERED POWER RATIO.

- › Filters "spin-on" type for quick maintenance
- › Full accessibility for easy and rapid maintenance and service.
- › Exclusive pneumatic control system, developed by ROTAIR, to adjust automatically engine revs, depending on the air to be delivered.
- › This system is highly reliable and ensures fuel consumption saving.
- › Start/stop "INTELLIGENT SYSTEM", exclusive from ROTAIR, to prevent the risk of incorrect procedures during specific functioning.
- › Air/oil separator filter, highly oversized, can guarantee an excellent air/oil separation.
- › The air and oil filters of the compressor and the air and oil filters of the engine are independent.
- › Single stage oversized air filter for compressor part, to guarantee good filtering of the air intake by airend.
- › Two-stage air filter for engine part.
- › Combined radiator allowing both compressor oil cooling and engine liquid cooling.



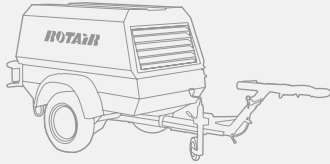

MDVN 46 K

800 kg / 1765 lbs (without brakes)
 856 kg / 1888 lbs (with brakes)
 780 kg / 1720 lbs (with skid adapters)

MDVN 53 K

800 kg / 1765 lbs (without brakes)
 856 kg / 1888 lbs (with brakes)
 780 kg / 1720 lbs (with skid adapters)

COMPRESSOR

	7 bar 102 psi	10 bar 145 psi	12 bar 174 psi	7 bar 102 psi	10 bar 145 psi	12 bar 174 psi
Operating pressure						
Free Air Delivery	4500 lt/min 159 cfm	3650 lt/min 129 cfm	3400 lt/min 120 cfm	5200 lt/min 184 cfm	4150 lt/min 147 cfm	3800 lt/min 134 cfm
Minimum working pressure	5 bar - 73 psi			5 bar - 73 psi		
Drive system engine-aiend	Direct Drive			Direct Drive		
Compressor cooling system	Air / Oil			Air / Oil		
Oil cooling capacity	10,5 lt - 2.3 UK gal			10,5 lt - 2.3 UK gal		
Outlet valves	2 x 3/4" + 1 x 1/1"			2 x 3/4" + 1 x 1/1"		
Noise level EECno 2000/14	< 98 LWA			< 98 LWA		
Battery capacity	12V cc - 680A-74Ah (EN)			12V cc - 680A-74Ah (EN)		
Fuel tank capacity	50 lt - 11 UK gal			50 lt - 11 UK gal		
Consumes	6,3 lt/h - 1.39 UK gal/h (7.9 working hours)			6,3 lt/h - 1.39 UK gal/h (7.9 working hours)		

DIESEL ENGINE

Engine make	KUBOTA	KUBOTA
Engine type	V-2403-M-DI	V-2403-M-DI
Engine system	4 strokes - Inline - Indirect Injection	4 strokes - Inline - Indirect Injection
Emissions	Stage III A / Tier 4 Interim	Stage III A / Tier 4 Interim
Displacement	2434 cc	2434 cc
N. cylinders	4	4
Aspiration	Natural	Natural
Max engine power @ 2450 rpm	35,5 kW - 48,3 CV	36,5 kW - 49,6 CV
Max engine speed	2450 rpm	2700 rpm
Min engine speed	1600 rpm	1600 rpm
Cooling system	Water	Water
Cooling system capacity	8 lt - 1.76 UK gal	8 lt - 1.76 UK gal
Lubrication system	Oil	Oil
Lubrication sys capacity	9 lt - 1.98 UK gal	9 lt - 1.98 UK gal

QUALITY OF AIR

Oil in air	1-3 PPM	1-3 PPM
Compressed air temperature	Ambient +40°C +72°F	Ambient +40°C +72°F

ENVIRONMENTAL CONDITIONS

Max altitude	1800 m a.s.l.	1800 m a.s.l.
Min/Max working temp.	-10°C / +50°C 14°F / 122°F	-10°C / +50°C 14°F / 122°F



MDVN 46 P-53 P



DESIGN WITH MODERN, SLENDER AND AGGRESSIVE LINE.

ELECTRO-GALVANIZED BODYWORK AND CHASSIS WITH ADVANCED PAINTING PROCEDURE TO GRANT AN EXCELLENT PRESERVATION THROUGH TIME.

LIGHT WEIGHT AND COMPACT DIMENSIONS FOR EASY HANDLING AND OPTIMUM DIMENSIONS / DELIVERED POWER RATIO.

- › Filters "spin-on" type for quick maintenance
- › Full accessibility for easy and rapid maintenance and service.
- › Exclusive pneumatic control system, developed by ROTAIR, to adjust automatically engine revs, depending on the air to be delivered.
- › This system is highly reliable and ensures fuel consumption saving.
- › Start/stop "INTELLIGENT SYSTEM", exclusive from ROTAIR, to prevent the risk of incorrect procedures during specific functioning.
- › Air/oil separator filter, highly oversized, can guarantee an excellent air/oil separation.
- › The air and oil filters of the compressor and the air and oil filters of the engine are independent.
- › Single stage oversized air filter for compressor part, to guarantee good filtering of the air intake by airend.
- › Two-stage air filter for engine part.
- › Combined radiator allowing both compressor oil cooling and engine liquid cooling.



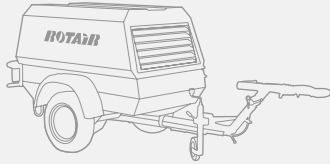

MDVN 46 P

850 kg / 1873 lbs (without brakes)
 870 kg / 1918 lbs (with brakes)
 780 kg / 1720 lbs (with skid adapters)

MDVN 53 P

850 kg / 1873 lbs (without brakes)
 870 kg / 1918 lbs (with brakes)
 720 kg / 1587 lbs (with skid adapters)

COMPRESSOR

	7 bar 102 psi	10 bar 145 psi	12 bar 174 psi	7 bar 102 psi	10 bar 145 psi	12 bar 174 psi
Operating pressure						
Free Air Delivery	4500 lt/min 159 cfm	3800 lt/min 134 cfm	3450 lt/min 122 cfm	5200 lt/min 184 cfm	4400 lt/min 155 cfm	4000 lt/min 141 cfm
Minimum working pressure	5 bar - 73 psi			5 bar - 73 psi		
Drive system engine-airend	Direct Drive			Direct Drive		
Compressor cooling system	Air / Oil			Air / Oil		
Oil cooling capacity	8 lt - 1.76 UK gal			8 lt - 1.76 UK gal		
Outlet valves	2 x 3/4" + 1 x 1"			2 x 3/4" + 1 x 1"		
Battery capacity	12V cc - 680A-74Ah (EN)			12V cc - 680A-74Ah (EN)		
Fuel tank capacity	50 lt - 11 UK gal			50 lt - 11 UK gal		
Consumes	6,1 lt/h - 1.34 UK gal/h (8.2 working hours)			6,9 lt/h - 1.52 UK gal/h (7.2 working hours)		

DIESEL ENGINE

Engine make	PERKINS	PERKINS
Engine type	404D-22	404D-22
Engine system	4 strokes - Inline	4 strokes - Inline
Emissions	Stage III A / Tier 2	Stage III A / Tier 2
Displacement	2216 cc	2216 cc
N. cylinders	4	4
Aspiration	Natural	Natural
Max engine power	35,5 kW - 48,3 CV (@2500 rpm)	37,9 kW - 51,5 CV (@2900 rpm)
Max engine speed	2500 rpm	2900 rpm
Min engine speed	1700 rpm	1700 rpm
Cooling system	Water	Water
Cooling system capacity	8 lt - 1.76 UK gal	8 lt - 1.76 UK gal
Lubrication system	Oil	Oil
Lubrication sys capacity	9 lt - 1.98 UK gal	9 lt - 1.98 UK gal

QUALITY OF AIR

Oil in air	1-3 PPM	1-3 PPM
Compressed air temperature	Ambient +40°C +72°F	Ambient +40°C +72°F

ENVIRONMENTAL CONDITIONS

Max altitude	1800 m a.s.l.	1800 m a.s.l.
Min/Max working temp.	-10°C / +50°C 14°F / 122°F	-10°C / +50°C 14°F / 122°F



D 200 Y



DESIGN WITH MODERN, SLENDER AND AGGRESSIVE LINE.

ELECTRO-GALVANIZED BODYWORK AND CHASSIS WITH ADVANCED PAINTING PROCEDURE TO GRANT AN EXCELLENT PRESERVATION THROUGH TIME.

LIGHT WEIGHT AND COMPACT DIMENSIONS FOR EASY HANDLING AND OPTIMUM DIMENSIONS / DELIVERED POWER RATIO.

- › Filters "spin-on" type for quick maintenance
- › Full accessibility for easy and rapid maintenance and service.
- › Exclusive pneumatic control system, developed by ROTAIR, to adjust automatically engine revs, depending on the air to be delivered.
- › This system is highly reliable and ensures fuel consumption saving.
- › Start/stop "INTELLIGENT SYSTEM", exclusive from ROTAIR, to prevent the risk of incorrect procedures during specific functioning.
- › Air/oil separator filter, highly oversized, can guarantee an excellent air/oil separation.
- › The air and oil filters of the compressor and the air and oil filters of the engine are independent.
- › Single stage oversized air filter for compressor part, to guarantee good filtering of the air intake by airend.
- › Two-stage air filter for engine part.
- › Combined radiator allowing both compressor oil cooling and engine liquid cooling.



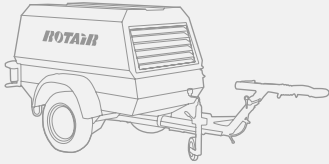

D 200 Y

820 kg / 1808 lbs (without brakes)
 875 kg / 1929 lbs (with brakes)
 800 kg / 1764 lbs (with skid adapters)

COMPRESSOR

Operating pressure	7 bar 102 psi	10 bar 145 psi	12 bar 174 psi
Free Air Delivery	5650 lt/min 200 cfm	3800 lt/min 134 cfm	3285 lt/min 116 cfm
Minimum working pressure	5 bar - 73 psi		
Drive system engine-airend	Direct drive		
Compressor cooling system	Air / Oil		
Oil cooling capacity	8 lt - 1.76 UK gal		
Outlet valves	3 x 3/4"		
Battery capacity	12V cc - 720A-80Ah (EN)		
Fuel tank capacity	50 lt - 11 UK gal		
Consumes	10,7 lt/h @100% - 6.4 lt/h @60% 2.35 UK gal/h @100% - 1.41 UK gal/h @60%		

DIESEL ENGINE

Engine make	YANMAR
Engine type	4TNV88 - DSAP
Engine system	4 strokes - Inline
Emissions	Stage III A / Tier 2
Displacement	2190 cc
N. cylinders	4
Aspiration	Natural
Max engine power @3000 rpm	35,4 kW - 48 CV
Max engine speed	3000 rpm
Min engine speed	1500 rpm
Cooling system	Water
Cooling system capacity	8 lt - 1.76 UK gal
Lubrication system	Oil
Lubrication system capacity	7,4 lt - 1.63 UK gal

QUALITY OF AIR

Oil in air	1-3 PPM
Compressed air temperature	Ambient +40°C +72°F

ENVIRONMENTAL CONDITIONS

Max altitude	1800 m a.s.l.
Min/Max working temperature	-10°C / +51°C 14°F / 124°F



MDVN 46-53 Eco5



DESIGN WITH MODERN, SLENDER AND AGGRESSIVE LINE.

ELECTRO-GALVANIZED BODYWORK AND CHASSIS WITH ADVANCED PAINTING PROCEDURE TO GRANT AN EXCELLENT PRESERVATION THROUGH TIME.

LIGHT WEIGHT AND COMPACT DIMENSIONS FOR EASY HANDLING AND OPTIMUM DIMENSIONS / DELIVERED POWER RATIO.

- › Filters "spin-on" type for quick maintenance
- › Full accessibility for easy and rapid maintenance and service.
- › European homologation for road circulation with and without brakes.
- › Exclusive pneumatic control system, developed by ROTAIR, to adjust automatically engine revs, depending on the air to be delivered. This system is highly reliable and ensures fuel consumption saving.
- › Start/stop "INTELLIGENT SYSTEM", exclusive from ROTAIR, to prevent the risk of incorrect procedures during specific functioning.
- › Air/oil separator filter, highly oversized, can guarantee an excellent air/oil separation.
- › The air and oil filters of the compressor and the air and oil filters of the engine are independent.
- › Single stage oversized air filter for compressor part, to guarantee good filtering of the air intake by airend.
- › Two-stage air filter for engine part.
- › Combined radiator allowing both compressor oil cooling and engine liquid cooling.



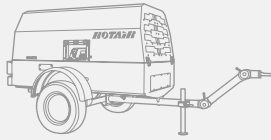

MDVN 46 Eco5

960 kg / 2116 lbs (without brakes)
 1105 kg / 2436 lbs (with brakes)
 970 kg / 2138 lbs (with skid adapters)

MDVN 53 Eco5

960 kg / 2116 lbs (without brakes)
 1105 kg / 2436 lbs (with brakes)
 970 kg / 2138 lbs (with skid adapters)

COMPRESSOR

	7 bar 102 psi	10 bar 145 psi	12 bar 174 psi	7 bar 102 psi	10 bar 145 psi	12 bar 174 psi
Operating pressure						
Free Air Delivery	4500 lt/min 159 cfm	3650 lt/min 129 cfm	3550 lt/min 125 cfm	5000 lt/min 177 cfm	4900 lt/min 175 cfm	3700 lt/min 132 cfm
Minimum working pressure	5 bar - 73 psi			5 bar - 73 psi		
Drive system engine-airend	Direct drive			Direct drive		
Compressor cooling system	Air / Oil			Air / Oil		
Oil cooling capacity	11 lt - 2.42 UK gal			11 lt - 2.42 UK gal		
Outlet valves	2 x 3/4"			2 x 3/4"		
Noise level EECno 2000/14	< 98 LWA			< 98 LWA		
Battery capacity	12V cc - 750A-100Ah (EN)			12V cc - 750A-100Ah (EN)		
Fuel tank capacity	88 lt - 19.36 UK gal			88 lt - 19.36 UK gal		
Consumes	10,4 lt/h @100% - 6,2 lt/h @60% 2.29 UK gal/h @100% - 1.37 UK gal/h @60%			10,4 lt/h @100% - 6,2 lt/h @60% 2.29 UK gal/h @100% - 1.37 UK gal/h @60%		

DIESEL ENGINE

Engine make	KOHLER	KOHLER
Engine type	KDI 1903 TCR St V	KDI 1903 TCR St V
Engine system	4 strokes - Inline - Indirect Injection	4 strokes - Inline - Indirect Injection
Emissions	Stage V / Tier 4 Final	Stage V / Tier 4 Final
Filtration	DOC + DPF	DOC + DPF
Displacement	1903 cc	1903 cc
N. cylinders	3	3
Aspiration	Turbo	Turbo
Max engine power @2450 rpm	36,5 kW - 49,6 CV	36,5 kW - 49,6 CV
Max engine speed	2350 rpm	2450 rpm
Min engine speed	1700 rpm	1700 rpm
Cooling system	Water	Water
Cooling system capacity	14 lt - 3.08 UK gal	14 lt - 3.08 UK gal
Lubrication system	Oil	Oil
Lubrication sys capacity	7 lt - 1.54 UK gal	7 lt - 1.54 UK gal

QUALITY OF AIR

Oil in air	1-3 PPM	1-3 PPM
Compressed air temperature	Ambient +40°C +72°F	Ambient +40°C +72°F

ENVIRONMENTAL CONDITIONS

Max altitude	1800 m a.s.l.	1800 m a.s.l.
Min/Max working temp.	-10°C / +45°C 14°F / 113°F	-10°C / +45°C 14°F / 113°F



MDVN 52 Eco5



DESIGN WITH MODERN, SLENDER AND AGGRESSIVE LINE.

ELECTRO-GALVANIZED BODYWORK AND CHASSIS WITH ADVANCED PAINTING PROCEDURE TO GRANT AN EXCELLENT PRESERVATION THROUGH TIME.

LIGHT WEIGHT AND COMPACT DIMENSIONS FOR EASY HANDLING AND OPTIMUM DIMENSIONS / DELIVERED POWER RATIO.

- › Filters "spin-on" type for quick maintenance
- › Full accessibility for easy and rapid maintenance and service.
- › European homologation for road circulation with and without brakes.
- › Exclusive pneumatic control system, developed by ROTAIR, to adjust automatically engine revs, depending on the air to be delivered. This system is highly reliable and ensures fuel consumption saving.
- › Start/stop "INTELLIGENT SYSTEM", exclusive from ROTAIR, to prevent the risk of incorrect procedures during specific functioning.
- › Air/oil separator filter, highly oversized, can guarantee an excellent air/oil separation.
- › The air and oil filters of the compressor and the air and oil filters of the engine are independent.
- › Single stage oversized air filter for compressor part, to guarantee good filtering of the air intake by airend.
- › Two-stage air filter for engine part.
- › Combined radiator allowing both compressor oil cooling and engine liquid cooling.



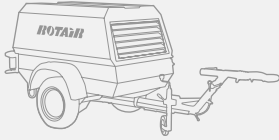

MDVN 52 Eco5

695 kg / 1532 lbs (without brakes)
745 kg / 1642 lbs (with brakes)
690 kg / 1521 lbs (with skid adapters)

COMPRESSOR

Operating pressure	7 bar 102 psi	10 bar 145 psi	12 bar 174 psi	14 bar 203 psi
Free Air Delivery	5200 l/min 184 cfm	4100 l/min 145 cfm	4050 l/min 143 cfm	3100 l/min 110 cfm
Minimum working pressure	5 bar - 73 psi			
Drive system engine-airend	Direct drive			
Compressor cooling system	Air / Oil			
Oil cooling capacity	8 l - 1.76 UK gal			
Outlet valves	2 x 3/4"			
Noise level EECno 2000/14	< 98 LWA			
Battery capacity	12V cc - 750A - 100Ah (EN)			
Fuel tank capacity	55 l - 12.1 UK gal			
Consumes	9,5 l/h - 2,1 UK gal/h @2300rpm			

DIESEL ENGINE

Engine make	HATZ
Engine type	3H50 TICD
Engine system	4 strokes - Diesel
Emissions	Stage V / Tier 4 Final
Displacement	1464 cc
N. cylinders	3
Aspiration	Turbo Intercooler
Max engine power @ 2800 rpm	42 kW - 57,1 CV
Max engine speed	2300 rpm
Min engine speed	2000 rpm
Cooling system	Water + Antifreeze
Cooling system capacity	8 l - 1.76 UK gal
Lubrication system	Oil
Lubrication sys capacity	5 l - 1.1 UK gal

QUALITY OF AIR

Oil in air	1-3 PPM
Compressed air temperature	Ambient +40°C +72°F

ENVIRONMENTAL CONDITIONS

Max altitude	1800 m a.s.l.
Min/Max working temp.	-10°C / +55°C 14°F / 122°F



MDVN 72Y



DESIGN WITH MODERN, SLENDER AND AGGRESSIVE LINE.

ELECTRO-GALVANIZED BODYWORK AND CHASSIS WITH ADVANCED PAINTING PROCEDURE TO GRANT AN EXCELLENT PRESERVATION THROUGH TIME.

LIGHT WEIGHT AND COMPACT DIMENSIONS FOR EASY HANDLING AND OPTIMUM DIMENSIONS / DELIVERED POWER RATIO.

- › Filters "spin-on" type for quick maintenance
- › Full accessibility for easy and rapid maintenance and service.
- › Exclusive pneumatic control system, developed by ROTAIR, to adjust automatically engine revs, depending on the air to be delivered.
- › This system is highly reliable and ensures fuel consumption saving.
- › Start/stop "INTELLIGENT SYSTEM", exclusive from ROTAIR, to prevent the risk of incorrect procedures during specific functioning.
- › Air/oil separator filter, highly oversized, can guarantee an excellent air/oil separation.
- › The air and oil filters of the compressor and the air and oil filters of the engine are independent.
- › Two stages oversized air filter for compressor part, to guarantee good filtering of the air intake by airend.
- › Two-stage air filter for engine part.
- › Combined radiator allowing both compressor oil cooling and engine liquid cooling.



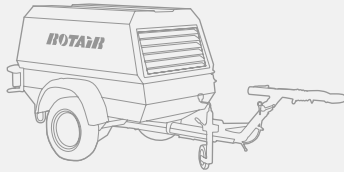

MDVN 72 Y

1240 kg / 2734 lbs (without brakes)
1215 kg / 2679 lbs (with skid adapters)

COMPRESSOR

Operating pressure	7 bar 102 psi	10 bar 145 psi	12 bar 174 psi
Free Air Delivery	7100 lt/min 251 cfm	6400 lt/min 226 cfm	4600 lt/min 162 cfm
Minimum working pressure	5,5 bar - 80 psi		
Drive system engine-airend	Direct drive		
Compressor cooling system	Air / Oil		
Outlet valves	2 x 3/4" + 1 x 1"		
Battery capacity	12V cc - 750A-100Ah (EN)		
Fuel tank capacity	90 lt - 19.8 UK gal		
Consumes	7,9 lt/h - 1.74 UK gal/h (11.4 working hours)		

DIESEL ENGINE

Engine make	YANMAR
Engine type	4TNV 98-NSAP
Engine system	4 strokes - Inline - Direct Injection
Emissions	Stage II / Tier 2
Displacement	3519 cc
N. cylinders	4
Aspiration	Natural
Max engine power @2400 rpm	48 kW - 65,3 CV
Max engine speed	2400 rpm
Min engine speed	1500 rpm
Cooling system	Water
Cooling system capacity	12 lt - 2.64 UK gal
Lubrication system	Oil

QUALITY OF AIR

Oil in air	≤ 3 PPM
Compressed air temperature	Ambient +40°C +72°F

ENVIRONMENTAL CONDITIONS

Max altitude	1800 m a.s.l.
Min/Max working temperature	-10°C / +50°C 14°F / 122°F



MDVN 80Y



DESIGN WITH MODERN, SLENDER AND AGGRESSIVE LINE.

ELECTRO-GALVANIZED BODYWORK AND CHASSIS WITH ADVANCED PAINTING PROCEDURE TO GRANT AN EXCELLENT PRESERVATION THROUGH TIME.

LIGHT WEIGHT AND COMPACT DIMENSIONS FOR EASY HANDLING AND OPTIMUM DIMENSIONS / DELIVERED POWER RATIO.

- › Filters "spin-on" type for quick maintenance
- › Full accessibility for easy and rapid maintenance and service.
- › Exclusive pneumatic control system, developed by ROTAIR, to adjust automatically engine revs, depending on the air to be delivered.
- › This system is highly reliable and ensures fuel consumption saving.
- › Start/stop "INTELLIGENT SYSTEM", exclusive from ROTAIR, to prevent the risk of incorrect procedures during specific functioning.
- › Air/oil separator filter, highly oversized, can guarantee an excellent air/oil separation.
- › The air and oil filters of the compressor and the air and oil filters of the engine are independent.
- › Two stages oversized air filter for compressor part, to guarantee good filtering of the air intake by airend.
- › Two-stage air filter for engine part.
- › Combined radiator allowing both compressor oil cooling and engine liquid cooling.



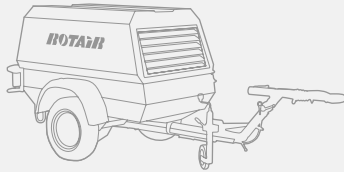

MDVN 80 Y

1240 kg / 2734 lbs (without brakes)
1240 kg / 2734 lbs (with brakes)
1215 kg / 2679 lbs (with skid adapters)

COMPRESSOR

Operating pressure	7 bar 102 psi	10 bar 145 psi	12 bar 174 psi
Free Air Delivery	7800 lt/min 275 cfm	6800 lt/min 240 cfm	4900 lt/min 173 cfm
Minimum working pressure	5,5 bar - 80 psi		
Drive system engine-airend	Direct drive		
Compressor cooling system	Air / Oil		
Outlet valves	2 x 3/4" + 1 x 1"		
Battery capacity	12V cc - 750A-100Ah (EN)		
Fuel tank capacity	90 lt - 19.8 UK gal		
Consumes	8,6 lt/h - 1.89 UK gal/h (10.4 working hours)		

DIESEL ENGINE

Engine make	YANMAR
Engine type	4TNV 98-NSAP
Engine system	4 strokes - Inline - Direct Injection
Emissions	Stage II / Tier 2
Displacement	3519 cc
N. cylinders	4
Aspiration	Natural
Max engine power @2500 rpm	50,7 kW - 68,9 CV
Max engine speed	2500 rpm
Min engine speed	1500 rpm
Cooling system	Water
Cooling system capacity	12 lt - 2.64 UK gal
Lubrication system	Oil

QUALITY OF AIR

Oil in air	≤ 3 PPM
Compressed air temperature	Ambient +40°C +72°F

ENVIRONMENTAL CONDITIONS

Max altitude	1800 m a.s.l.
Min/Max working temperature	-10°C / +50°C 14°F / 122°F



MDVN 83 Eco5



**DESIGN WITH MODERN, SLENDER
AND AGGRESSIVE LINE.**

**ELECTRO-GALVANIZED BODYWORK
AND CHASSIS WITH ADVANCED
PAINTING PROCEDURE TO GRANT
AN EXCELLENT PRESERVATION
THROUGH TIME.**

**LIGHT WEIGHT AND
COMPACT DIMENSIONS FOR
EASY HANDLING AND OPTIMUM
DIMENSIONS / DELIVERED
POWER RATIO.**

- › Kohler Stage V-Tier Final compliant, with aftertreatment system DOC+DPF
- › Full accessibility for easy and rapid maintenance and service.
- › European homologation for road circulation with and without brakes.
- › Exclusive pneumatic control system, developed by ROTAIR, to adjust automatically engine revs, depending on the air to be delivered. This system is highly reliable and ensures fuel consumption saving.
- › Start/stop "INTELLIGENT SYSTEM", exclusive from ROTAIR, to prevent the risk of incorrect procedures during specific functioning.
- › Air/oil separator filter, highly oversized, can guarantee an excellent air/oil separation.
- › The air and oil filters of the compressor and the air and oil filters of the engine are independent.
- › Single stage oversized air filter for compressor part, to guarantee good filtering of the air intake by airend.
- › Two-stage air filter for engine part.
- › Combined radiator allowing both compressor oil cooling and engine liquid cooling.



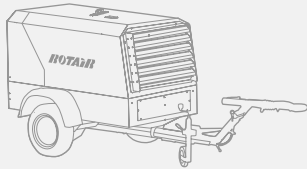

MDVN 83 Eco5

1320 kg / 2910 lbs (without brakes)

1395 kg / 3075 lbs (with brakes)

1330 kg / 2932 lbs (with skid adapters)

COMPRESSOR

Operating pressure	7 bar 102 psi	10 bar 145 psi	12 bar 174 psi
Free Air Delivery	8000 lt/min 283 cfm	6400 lt/min 226 cfm	5600 lt/min 198 cfm
Minimum working pressure	5 bar - 73 psi		
Drive system engine-arend	Direct drive		
Compressor cooling system	Air / Oil		
Oil cooling capacity	16 lt - 3.52 UK gal		
Outlet valves	2 x 3/4"+ 1 x 1"		
Noise level EECno 2000/14	< 98 LWA		
Battery capacity	12V cc - 950A-132Ah (EN)		
Fuel tank capacity	140 lt - 30.80 UK gal		
Consumes	13,4 lt/h @100% - 7,2 lt/h @60% 2.95 UK gal/h @100% - 1.58 UK gal/h @60%		

DIESEL ENGINE

Engine make	KOHLER
Engine type	KDI 2504-TCR St V
Engine system	4 strokes - Inline - Indirect Injection
Emissions	Stage V / Tier 4 Final
Filtration	DOC + DPF
Displacement	2482 cc
N. cylinders	4
Aspiration	Turbo
Max engine power @2100 rpm	55 kW - 74,8 CV
Max engine speed	2100 rpm
Min engine speed	1700 rpm
Cooling system	Water
Cooling system capacity	18 lt - 3.96 UK gal
Lubrication system	Oil
Lubrication system capacity	11 lt - 2.42 UK gal

QUALITY OF AIR

Oil in air	≤ 3 PPM
Compressed air temperature	Ambient +40°C +72°F

ENVIRONMENTAL CONDITIONS

Max altitude	1800 m a.s.l.
Min/Max working temp.	-10°C / +50°C 14°F / 122°F



MDVN 100 K



DESIGN WITH MODERN, SLENDER AND AGGRESSIVE LINE.

ELECTRO-GALVANIZED BODYWORK AND CHASSIS WITH ADVANCED PAINTING PROCEDURE TO GRANT AN EXCELLENT PRESERVATION THROUGH TIME.

LIGHT WEIGHT AND COMPACT DIMENSIONS FOR EASY HANDLING AND OPTIMUM DIMENSIONS / DELIVERED POWER RATIO.

- › Filters "spin-on" type for quick maintenance
- › Full accessibility for easy and rapid maintenance and service.
- › Exclusive pneumatic control system, developed by ROTAIR, to adjust automatically engine revs, depending on the air to be delivered.
- › This system is highly reliable and ensures fuel consumption saving.
- › Start/stop "INTELLIGENT SYSTEM", exclusive from ROTAIR, to prevent the risk of incorrect procedures during specific functioning.
- › Air/oil separator filter, highly oversized, can guarantee an excellent air/oil separation.
- › The air and oil filters of the compressor and the air and oil filters of the engine are independent.
- › Two stages oversized air filter for compressor part, to guarantee good filtering of the air intake by airend.
- › Two-stage air filter for engine part.
- › Combined radiator allowing both compressor oil cooling and engine liquid cooling.



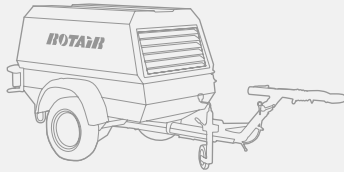

MDVN 100 K

COMPRESSOR

Operating pressure	7 bar 102 psi	10 bar 145 psi	12 bar 174 psi
Free Air Delivery	10360 lt/min 366 cfm	8800 lt/min 311 cfm	7800 lt/min 275 cfm
Minimum working pressure	5,5 bar - 80 psi		
Drive system engine-arend	Direct drive		
Compressor cooling system	Air / Oil		
Outlet valves	2 x 3/4" + 1 x 1"		
Battery capacity	12V cc - 750A-100Ah (EN)		
Fuel tank capacity	92 lt - 20.24 UK gal		
Consumes	8,9 lt/h - 1.96 UK gal/h (10,3 working hours)		

DIESEL ENGINE

Engine make	KUBOTA
Engine type	V3800DI-T
Engine system	Vertical, water cooled 4-cycle DI diesel engine
Emissions	Stage III a
Displacement	3769 cc
N. cylinders	4
Aspiration	Turbocharged
Max engine power @2500 rpm	74 kW - 100,6 CV
Max engine speed	2600 rpm
Cooling system	Pressurized radiator, forced circulation with water pump
Lubrication system	Forced lubrication by trochoid pump

QUALITY OF AIR

Oil in air	< 3 PPM
Compressed air temperature	Ambient +40°C +72°F

ENVIRONMENTAL CONDITIONS

Max altitude	1800 m a.s.l.
Min/Max working temperature	-10°C / +50°C 14°F / 122°F



ABRASIVE BLASTING MODE

AFTER COOLED

SAND BLASTING

The treatment of compressed air is becoming an increasingly crucial aspect when it comes to managing the wide range of applications it is used for. To address this, **ROTAIR** provides an aftercooler and moisture separator option for all compressors in our lineup.

The role of an aftercooler is essential: it helps lower the temperature of compressed air and, more importantly, reduces its relative humidity by eliminating condensate. Most of our compressors come with the option of an onboard aftercooler, and some models, like the VRK+, even feature a dual-stage integrated aftercooling system.

INBUILT ADDITIONAL COOLER AND SPECIFIC CONDENSATE SEPARATOR

for cool and dry air

specifically
designed for...



In some cases, an external aftercooler may be more suitable. It's useful when there is an occasional need to enhance a standard compressor or when the point of application is further away, ensuring the air quality remains consistent over a longer hose length.

These are "Plug & Play" solutions designed to provide cool, condensate-free compressed air exactly when you need it. For even more demanding needs, **ROTAIR** offers a version that includes additional fine filters, ensuring the air is technically oil-free.

Whether integrated, external, or additional, the aftercooler and moisture separator option makes **ROTAIR** compressors ideal for a variety of applications requiring cooler, drier air—such as abrasive blasting, fiber blowing, dry-ice cleaning, and many others.

The undercarriage of a portable compressor is composed of:

AXLE

The part connecting compressor to the ground, includes suspension system, wheels and all related parts. Suspensions can be assured with springs (sprung axle) or leaf springs (leaf spring axle). Wheels are of different size, to match the weight of the machine and according to the type of towing.

LIGHTS

System of rear lights and reflectors

BRAKING SYSTEMS

Can be with no braking system at all, simple parking brake or repulsion braking system.

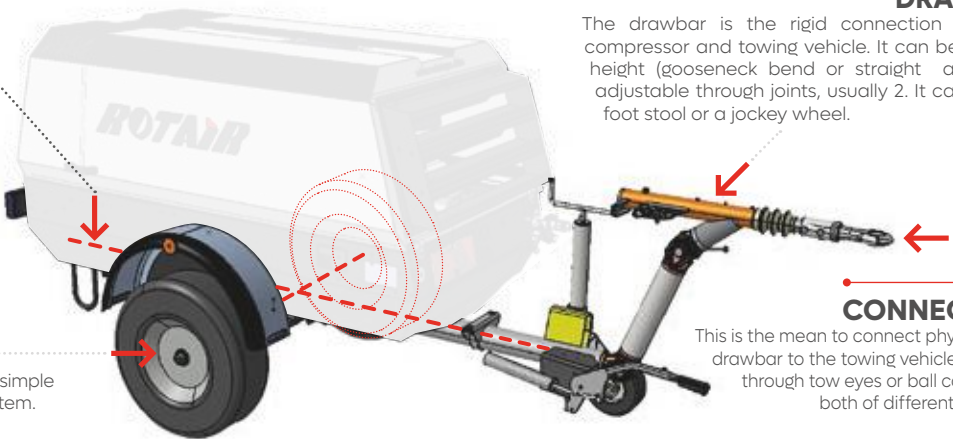

DRAWBAR

The drawbar is the rigid connection between compressor and towing vehicle. It can be at fixed height (gooseneck bend or straight angles) or adjustable through joints, usually 2. It can have a foot stool or a jockey wheel.

CONNECTION

This is the mean to connect physically the drawbar to the towing vehicle. It can be through tow eyes or ball connection, both of different diameter.

STANDARD TRAILER - MDVN

So-called "gooseneck" for the peculiar shape of the drawbar. Is always without brakes. Enables slow towing (max 25 km/h) on work field but not on public roads.

TRAILER WITH BRAKES - MDVN

Has adjustable drawbar, repulsive braking system, lights. Enables compressor to be towed on public roads, if homologated.

STANDARD TRAILER - MDVS

Has adjustable drawbar. Is without repulsive braking system, but has a parking brake. Enables slow towing (max 25 km/h) on work field but not on public roads.

TRAILER WITH BRAKES - MDVS

Has adjustable drawbar, repulsive braking system, lights. Enables compressor to be towed on public roads, if homologated.

TRAILER WITH PARKING BRAKE

All types of axles and drawbars can be equipped with parking brake, a lever that blocks the wheels when the machine must be static.

SKID ADAPTOR

Portable compressors can be delivered "ON SKID", which means without wheels but on a base with four support feet.

ROTAIR has a special SKID ADAPTOR, used to prepare the machine for standard skid delivery, that can be provided as separate attachment and be used to transform a towable compressor into a skid compressor. Viceversa: by removing the skid adaptor and installing an undercarriage with all its parts, the original skid machine can become towable.



ON ROAD HOMOLOGATION / To circulate on public roads, towed by a vehicle, a portable compressor needs to have several characteristics.

EUROPE:

European Union has uniformed the legislation to enable towing of trailers, among those portable compressors. To be towed on public roads, a trailer shall respond to Directive 2007/46/CE. The manufacturer shall undergo a process of internal homologation by one European Ministry of transports and all machines to be towed shall be examined and approved. The exam includes the presence of all elements requested by the Directive (among others: braking system where needed, lights, reflectors, etc..). This done, the manufacturer will be issued, for each towable model, a unique reference number, that will be engraved on the chassis of the machines deemed to be towed and integrated into the specific documentation of the machine. This number, communicated by the end Customer to the Office of Circulation of the European Country where the machine will be put into operation, will enable the road homologation process without need of further presentation of documents or physical inspection and assessment by the competent Authority.

OTHER COUNTRIES.

For other Countries outside Europe, the local legislation shall be followed. ROTAIR can provide, upon request, the specific documents and drawings that could be requested for a national road homologation. The Dealer or end Customer shall provide the specifications that the machines shall respect to be homologated. In some cases, the Dealer could modify the machines, upon authorization of ROTAIR, to conform them to the norms of the reference Country.

FEATURED HIGHLIGHTS

EXCLUSIVE ROTAIR INTELLIGENT SYSTEM

THE "INTELLIGENT SYSTEM" ENABLES A PRE-HEATING OF THE ENGINE WITHOUT OVERLOADING IT, THE AIREND WILL START WORKING ONLY WHEN THE PERFECT CONDITIONS ARE REACHED.

THE SAME IN TURNING OFF THE MACHINE AFTER A DEPRESSURISATION PHASE OF THE HYDRAULIC CIRCUIT, NO HAMMERING OF THE AIREND DUE TO ITS INERTIAL MOVEMENT, BUT A GRADUAL TURN-OFF.

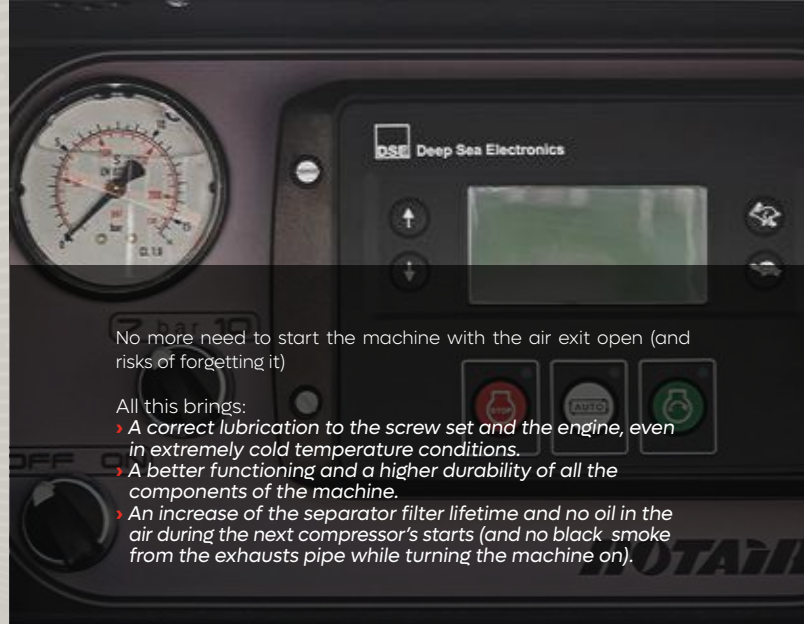

No more need to start the machine with the air exit open (and risks of forgetting it)

All this brings:

- › A correct lubrication to the screw set and the engine, even in extremely cold temperature conditions.
- › A better functioning and a higher durability of all the components of the machine.
- › An increase of the separator filter lifetime and no oil in the air during the next compressor's starts (and no black smoke from the exhausts pipe while turning the machine on).



BUNDED CHASSIS ADAPTER

This exclusive device, only for ROTAIR portable compressors, offers the possibility to have your compressor protected from accidental spills of fluids on the ground.

Removable yet solidly fixable to the compressor, it is the ultimate option where anti-spill is mandatorily required.

It is so intelligent that it enables forklift handling of the compressor.

EASY MAINTENANCE

FULL ACCESSIBILITY
FOR EASY AND RAPID
MAINTENANCE AND
SERVICE



PORTABLE
COMPRESSORS
GENERAL RANGE

**WARRANTY
DURATION
RELIABILITY**

are assured with
THE EXCLUSIVE USE
of original spare parts

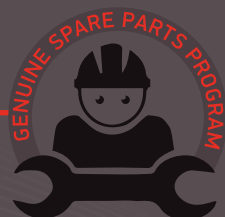

rotairspa.com



© 2024 | ALL RIGHTS RESERVED

ROT*Ai*R[®]
Delivering **WORLD CLASS** Compressors

PORTABLE COMPRESSORS GENERAL RANGE

ROTAIR
Delivering **WORLD CLASS** Compressors

Via Bernezzo, 67
12023 › Caraglio (Cn) › ITALY

Ph: +39 0171 619676

rotairspa.com
info@rotairspa.com



Azienda certificata
ISO 9001:2015

