

**ROTAIR**



SPECIFIC  
EUROPE

GOMMAIR | MOVN | MDVS | VRK | TVR | VRH

**STAGE**

**V**

**PORTABLE  
COMPRESSORS**

**PRO  
SERIES**



Reducing Emissions

**NOW!**

delivering  
WORLD-CLASS Compressors





# VRK 16-20



**COMPACT AND EXTREMELY  
MANEUVERABLE MACHINE  
DESIGNED FOR EASY ACCESS  
AND MAINTENANCE.**

**ALL FILTERS READILY ACCESSIBLE,  
EASY TO TRANSPORT AND  
IMMEDIATELY READY TO WORK.**

**ALL MOVING PARTS ARE  
INACCESSIBLE, ACCORDING  
TO THE MOST STRINGENT  
SAFETY NORMS.**

- › ROTAIR System for proportional acceleration at air demand:
  - ›› Less noise and consumption
  - ›› Power all declinated to air flow
- › Petrol tank in sight & extractable for practical refuelling
- › All filters are spin-on / bayonet-type, for faster change
- › Intuitive starter / Integrated hours counter / Manometer / Thermostat with safety arrest @ high temperatures
- › Start / Stop @ low pressures for longer life of machine and components
- › Cooling ventilator shielded and protected.
- › Muffler under the machine, less noise and avoids risks of accidental burns.

- › Lifting eye for crane use.  
Solid-type wheels.  
Skid version available on option.
- › High efficiency trapezoidal belt-drive, over-dimensioned to ensure transmission with less maintenance.
- › Double-stage air / oil separation  
Lowest oil in air for this category:  
1-3 PPM!
- › Compressor air filter and engine air filter are separated.
- › Single stage oversized air filter for compression circuit, to guarantee good filtering of the air intaken by airend.



## VRK 16

230 kg / 507 lbs  
230 kg / 507 lbs (with skid adapters)

## VRK 20

230 kg / 507 lbs  
230 kg / 507 lbs (with skid adapters)

### COMPRESSOR

	6 bar 87 psi	11 bar 160 psi	13 bar 188 psi	6 bar 87 psi	11 bar 160 psi	13 bar 188 psi
Operating pressure						
Free Air Delivery	1600 lt/min 57 cfm	1100 lt/min 39 cfm	950 lt/min 34 cfm	1900 lt/min 67 cfm	1250 lt/min 44 cfm	1100 lt/min 39 cfm
Minimum working pressure	5,5 bar - 80 psi			5,5 bar - 80 psi		
Drive system engine-airend	Belt-drive XPZ overdimensioned			Belt-drive XPZ overdimensioned		
Compressor cooling system	Air / Oil			Air / Oil		
Oil cooling capacity	5 lt / 1.1 UK gal			5 lt / 1.1 UK gal		
Outlet valves	1 x 3/4"			1 x 3/4"		
Noise level EECno 2000/14	< 97 LWA			< 97 LWA		
Battery capacity	12V cc - 330A - 45Ah (EN)			12V cc - 330A - 45Ah (EN)		
Fuel tank capacity	15 lt / 3.3 UK gal			15 lt / 3.3 UK gal		

### PETROL ENGINE

	HONDA	HONDA
Engine make	HONDA	HONDA
Engine type	GX 630	GX 690
Engine system	4 strokes	4 strokes
Emissions	Stage V	Stage V
Displacement	688 cc	688 cc
N. cylinders	2	2
Aspiration	Natural	Natural
Max engine power @3600 rpm	15,5 kW - 21 CV	16,5 kW-22,5 CV
Max engine speed	3000 rpm	3000 rpm
Min engine speed	2100 rpm	2000 rpm
Cooling system	Air	Air
Lubrication system	Oil	Oil
Lubrication sys capacity	1,9 lt / 0.42 UK gal	1,9 lt / 0.42 UK gal

### QUALITY OF AIR

Oil in air	1-3 PPM	1-3 PPM
Compressed air temperature	Ambient +40°C   +72°F	Ambient +40°C   +72°F

### ENVIRONMENTAL CONDITIONS

Max altitude	1800 m a.s.l.	1800 m a.s.l.
Min/Max working temp.	-10°C / +50°C   14°F / 122°F	-10°C / +50°C   14°F / 122°F



# ABRASIVE BLASTING MODE

## AFTER COOLED

## ABRASIVE BLASTING

The treatment of compressed air is becoming an increasingly crucial aspect when it comes to managing the wide range of applications it is used for. To address this, **ROTAIR** provides an aftercooler and moisture separator option for all compressors in our lineup.

The role of an aftercooler is essential: it helps lower the temperature of compressed air and, more importantly, reduces its relative humidity by eliminating condensate. Most of our compressors come with the option of an onboard aftercooler, and some models, like the VRK+, even feature a dual-stage integrated aftercooling system.

## INBUILT ADDITIONAL COOLER AND SPECIFIC CONDENSATE SEPARATOR

*for cool and dry air*

*specifically*  
designed for...



In some cases, an external aftercooler may be more suitable. It's useful when there is an occasional need to enhance a standard compressor or when the point of application is further away, ensuring the air quality remains consistent over a longer hose length.

These are "Plug & Play" solutions designed to provide cool, condensate-free compressed air exactly when you need it. For even more demanding needs, **ROTAIR** offers a version that includes additional fine filters, ensuring the air is technically oil-free.

Whether integrated, external, or additional, the aftercooler and moisture separator option makes **ROTAIR** compressors ideal for a variety of applications requiring cooler, drier air—such as abrasive blasting, fiber blowing, dry-ice cleaning, and many others.

### AXLE

The part connecting compressor to the ground, includes suspension system, wheels and all related parts. Suspensions can be assured with springs (sprung axle) or leaf springs (leaf spring axle). Wheels are of different size, to match the weight of the machine and according to the type of towing.

### LIGHTS

System of rear lights and reflectors

### BRAKING SYSTEMS

Can be with no braking system at all, simple parking brake or repulsion braking system.

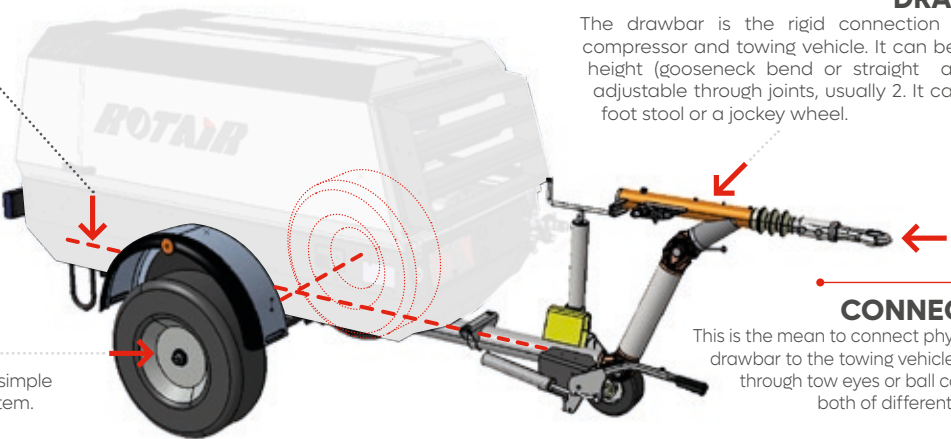

### DRAWBAR

The drawbar is the rigid connection between compressor and towing vehicle. It can be at fixed height (gooseneck bend or straight angles) or adjustable through joints, usually 2. It can have a foot stool or a jockey wheel.

### CONNECTION

This is the mean to connect physically the drawbar to the towing vehicle. It can be through tow eyes or ball connection, both of different diameter.

### STANDARD TRAILER - MDVN

So-called "gooseneck" for the peculiar shape of the drawbar. Is always without brakes. Enables slow towing (max 25 km/h) on work field but not on public roads.

### TRAILER WITH BRAKES - MDVN

Has adjustable drawbar, repulsive braking system, lights. Enables compressor to be towed on public roads, if homologated.

### STANDARD TRAILER - MDVS

Has adjustable drawbar. Is without repulsive braking system, but has a parking brake. Enables slow towing (max 25 km/h) on work field but not on public roads.

### TRAILER WITH BRAKES - MDVS

Has adjustable drawbar, repulsive braking system, lights. Enables compressor to be towed on public roads, if homologated.

### TRAILER WITH PARKING BRAKE

All types of axles and drawbars can be equipped with parking brake, a lever that blocks the wheels when the machine must be static.

### SKID ADAPTOR

Portable compressors can be delivered "ON SKID", which means without wheels but on a base with four support feet.

**ROTAIR has a special SKID ADAPTOR**, used to prepare the machine for standard skid delivery, that can be provided as separate attachment and be used to transform a towable compressor into a skid compressor. Viceversa: by removing the skid adaptor and installing an undercarriage with all its parts, the original skid machine can become towable.



**ON ROAD HOMOLOGATION** / To circulate on public roads, towed by a vehicle, a portable compressor needs to have several characteristics.

#### EUROPE:

European Union has uniformed the legislation to enable towing of trailers, among those portable compressors. To be towed on public roads, a trailer shall respond to Directive 2007/46/CE. The manufacturer shall undergo a process of internal homologation by one European Ministry of transports and all machines to be towed shall be examined and approved. The exam includes the presence of all elements requested by the Directive (among others: braking system where needed, lights, reflectors, etc..). This done, the manufacturer will be issued, for each towable model, a unique reference number, that will be engraved on the chassis of the machines deemed to be towed and integrated into the specific documentation of the machine. This number, communicated by the end Customer to the Office of Circulation of the European Country where the machine will be put into operation, will enable the road homologation process without need of further presentation of documents or physical inspection and assessment by the competent Authority.

#### OTHER COUNTRIES.

For other Countries outside Europe, the local legislation shall be followed. ROTAIR can provide, upon request, the specific documents and drawings that could be requested for a national road homologation. The Dealer or end Customer shall provide the specifications that the machines shall respect to be homologated. In some cases, the Dealer could modify the machines, upon authorization of ROTAIR, to conform them to the norms of the reference Country.

# FEATURED HIGHLIGHTS

## EXCLUSIVE ROTAIR INTELLIGENT SYSTEM

---

THE "INTELLIGENT SYSTEM" ENABLES A PRE-HEATING OF THE ENGINE WITHOUT OVERLOADING IT, THE AIREND WILL START WORKING ONLY WHEN THE PERFECT CONDITIONS ARE REACHED.

THE SAME IN TURNING OFF THE MACHINE AFTER A DEPRESSURISATION PHASE OF THE HYDRAULIC CIRCUIT, NO HAMMERING OF THE AIREND DUE TO ITS INERTIAL MOVEMENT, BUT A GRADUAL TURN-OFF.

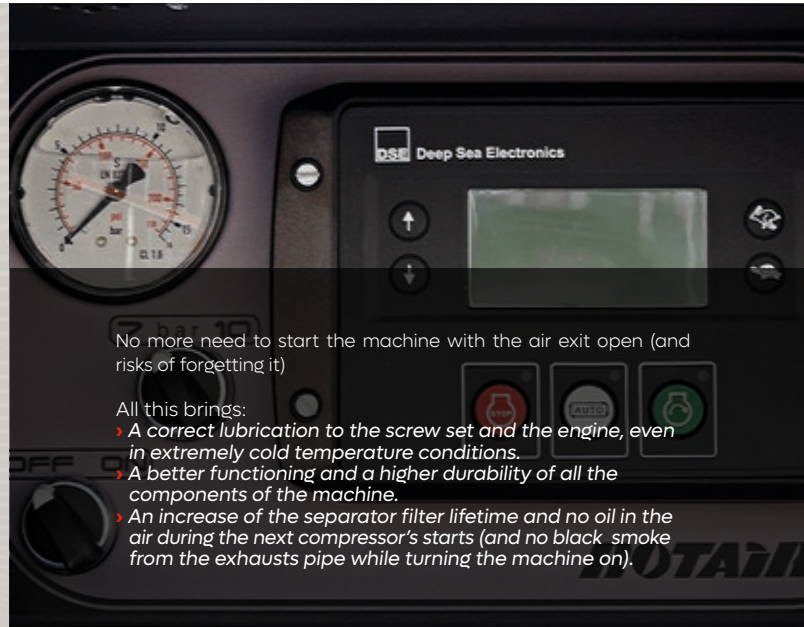

No more need to start the machine with the air exit open (and risks of forgetting it)

All this brings:

- › A correct lubrication to the screw set and the engine, even in extremely cold temperature conditions.
- › A better functioning and a higher durability of all the components of the machine.
- › An increase of the separator filter lifetime and no oil in the air during the next compressor's starts (and no black smoke from the exhausts pipe while turning the machine on).

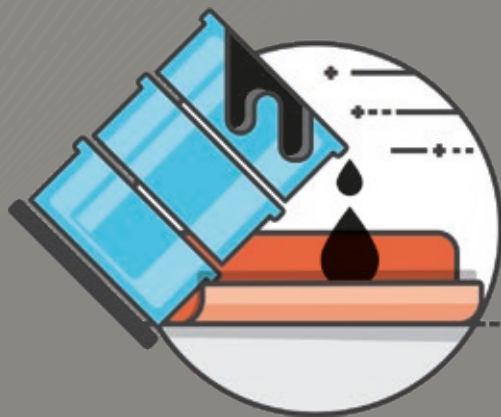

## BUNDED CHASSIS ADAPTER

---

This exclusive device, only for ROTAIR portable compressors, offers the possibility to have your compressor protected from accidental spills of fluids on the ground.

Removable yet solidly fixable to the compressor, it is the ultimate option where anti-spill is mandatorily required.

It is so intelligent that it enables forklift handling of the compressor.

## EASY MAINTENANCE

---

FULL ACCESSIBILITY  
FOR EASY AND RAPID  
MAINTENANCE AND  
SERVICE

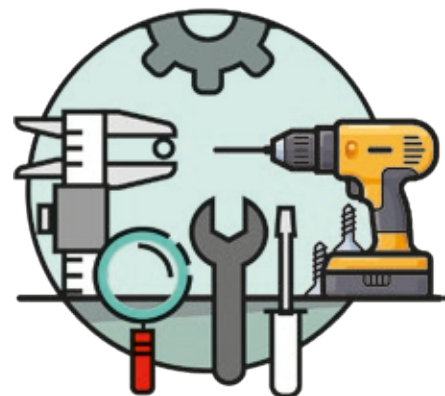

# STAGE V

PORTABLE COMPRESSORS | PRO SERIES

**WARRANTY  
DURATION  
RELIABILITY**

are assured with  
THE EXCLUSIVE USE  
of original spare parts

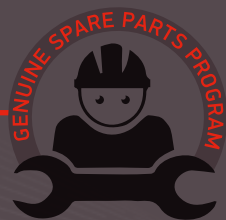



[rotairspa.com](http://rotairspa.com)



© 2024 | ALL RIGHTS RESERVED

**ROT*Ai*R**<sup>®</sup>  
Delivering **WORLD CLASS** Compressors

# STAGE V

**PORTABLE COMPRESSORS** | **PRO SERIES**

Via Bernezzo, 67  
12023 ▶ Caraglio (Cn) ▶ ITALY

Ph: +39 0171 619676

[rotairspa.com](http://rotairspa.com)  
[info@rotairspa.com](mailto:info@rotairspa.com)

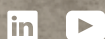

**ROTAIR**  
Delivering **WORLD CLASS** Compressors

Azienda certificata  
**ISO 9001:2015**

